



**This seat
is your partner**

Universal Seat
for Construction Machines

ISRI® 6000/577

Mechanical suspension
ISRI® driver's seat
Proven standards
for safety and comfort

The ISRI® 6000/577 is a comfort driver's seat for construction machines. It is of extraordinary quality and extremely robust. Depending on the vehicle category, the mechanical suspension system can be delivered in different versions according to EN/ISO 7096:2000. The additional reinforcements within the seat make the ISRI® 6000/577 compliant with all current DIN and EN safety requirements. The variety of individually adjustable features, compliment the standard height and inclination adjustment system. These features work in relation with the anatomically formed seat and backrest cushions to minimise driver fatigue. All seats are equipped with extremely durable and robust upholstery.

STANDARD FITTING

- Horizontal adjustment, double locking, 180 mm
- Weight adjustment, infinitely up to 130 kg
- Suspension stroke, 95 mm
- Height and inclination adjustment, in fine increments up to 65 mm
- Two seat belt fixing points, corresponding to latest standards

ACCESSORIES

- Armrests with infinite angular adjustment
- Heating elements in seat cushion and backrest, with on/off switch
- Adjustable lumbar support
- Automatic lap belt
- Security head restraint, adjustable in height and rake
- Vinyl cover



Refined ideas
and technology -
with security. ISRI®

ISRI® 6000/577

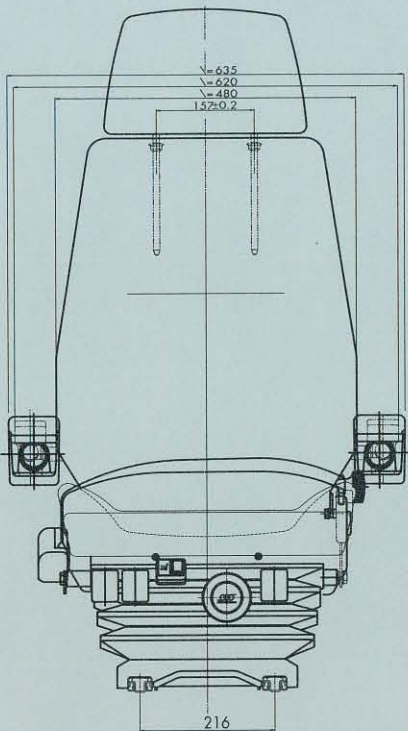
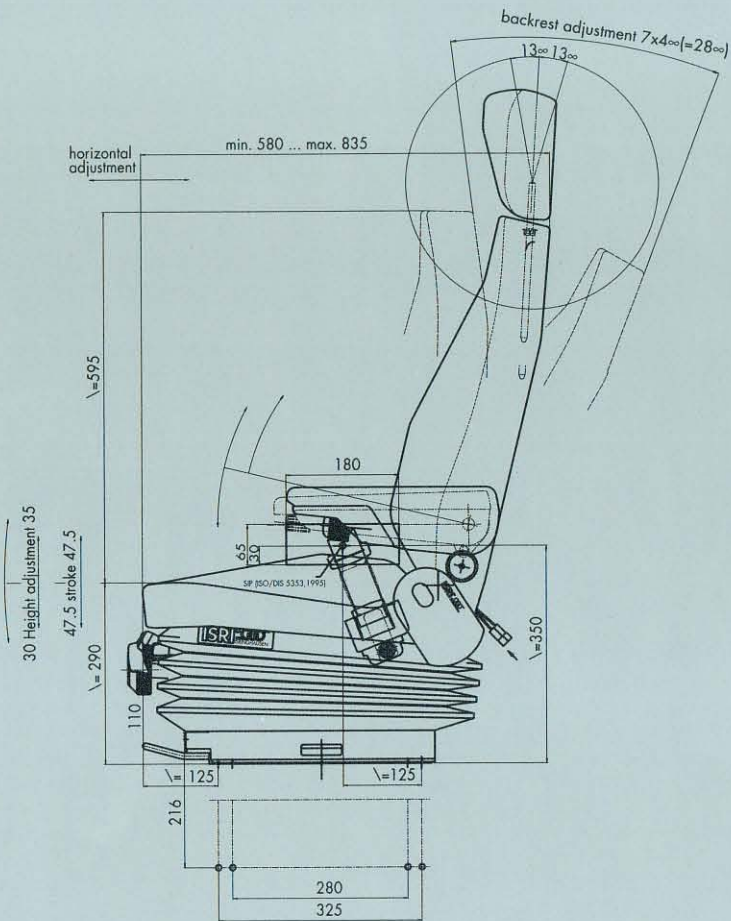

- Height and inclination adjustment
- Heating elements
- Horizontal adjustment
- Weight adjustment
- Backrest adjustment



ISRINGHAUSEN
GMBH & CO. KG
An der Bega 58
32657 Lemgo · Germany
Fon +49 (0) 52 612 10-0
Fax +49 (0) 52 612 10-310
www.isri.de
info@isri.de

Please pay attention to
installation guidelines of
vehicle manufacturers.

Technical changes
reserved.
Issue 04/02